



**ELECTROMAGNETICS
SPECIALISTS**

Parameters, Variables and Equations

Volker Mühlhaus
volker@muehlhaus.com

Sonnet Parameters

- In Sonnet 12 and later, we can use variables and equations for:
 - geometry parameters
 - material properties

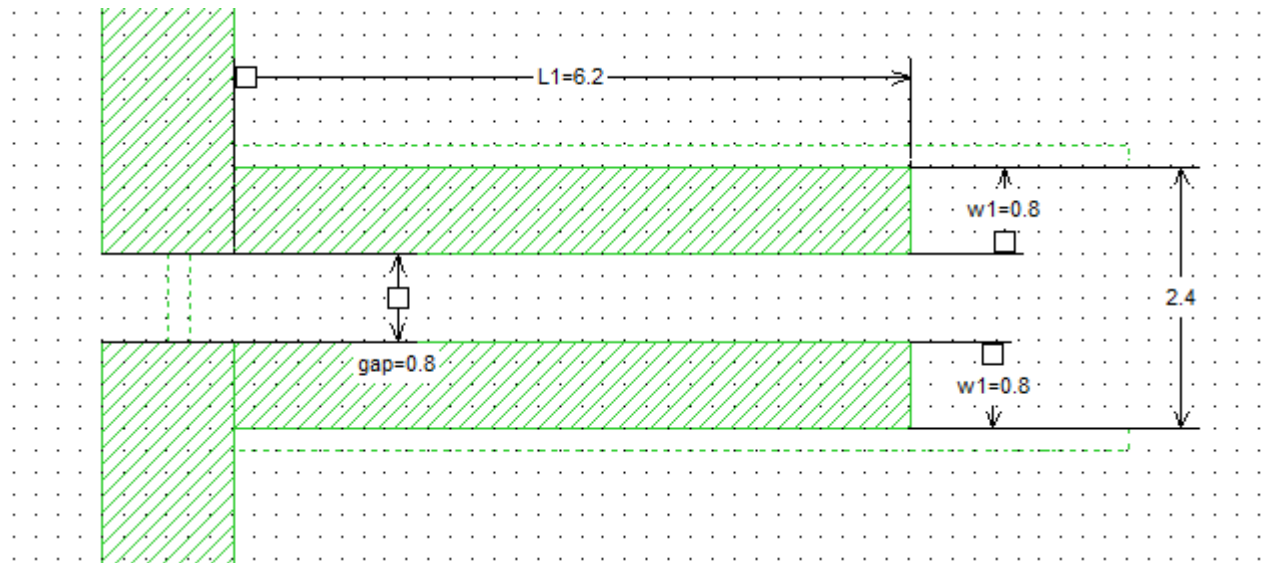

Geometry Parameters

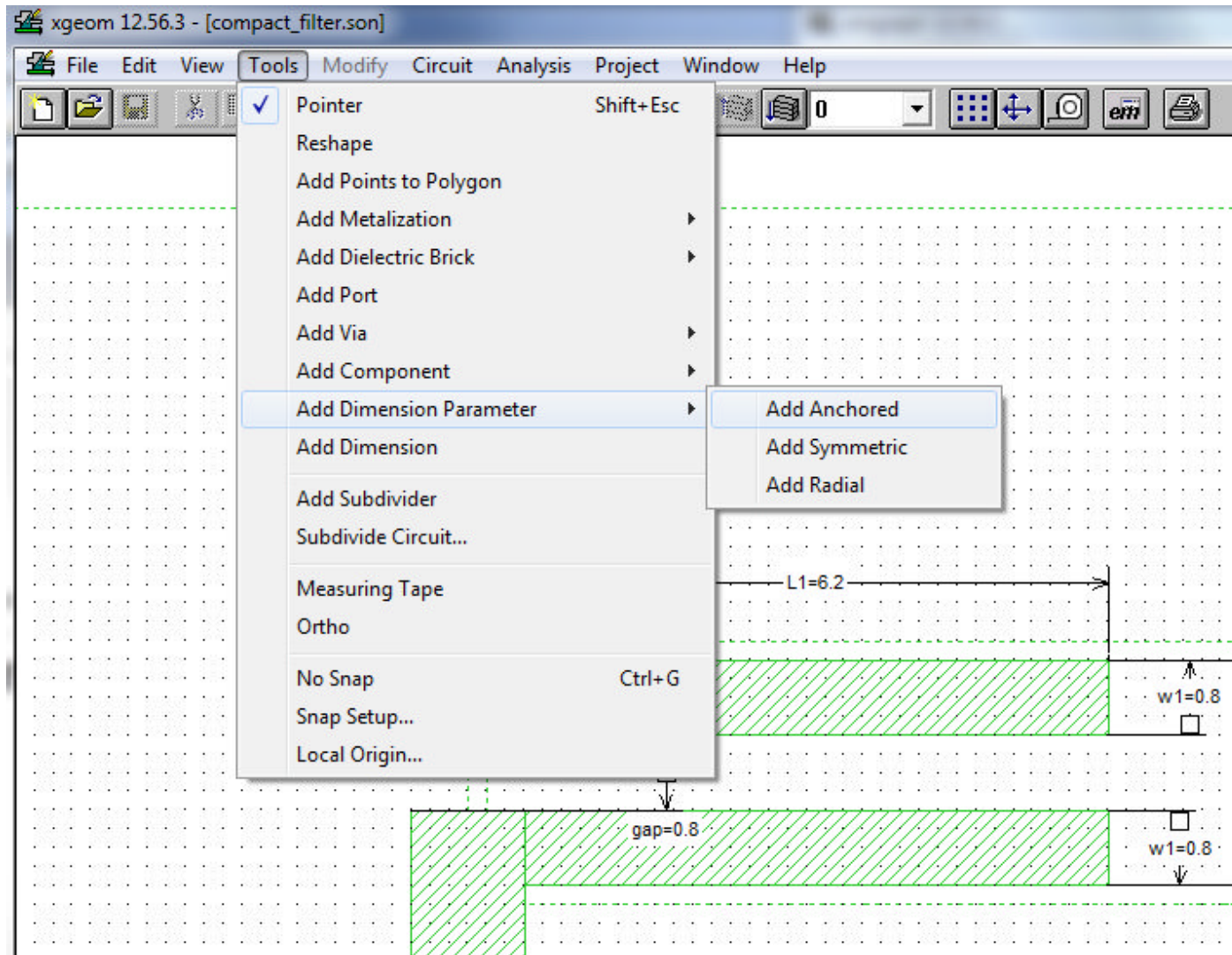

Anchored

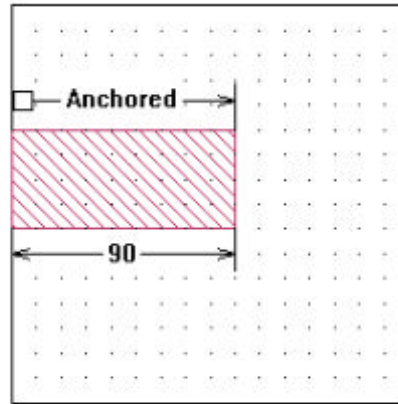

Nominal Value = 90 mils

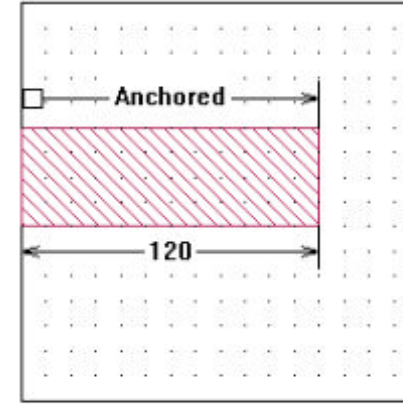

Nominal Value = 120 mils

Symmetric

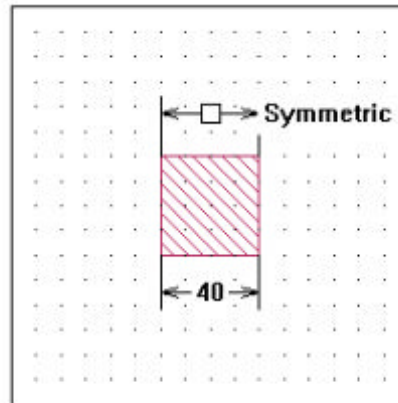

Nominal Value = 40 mils

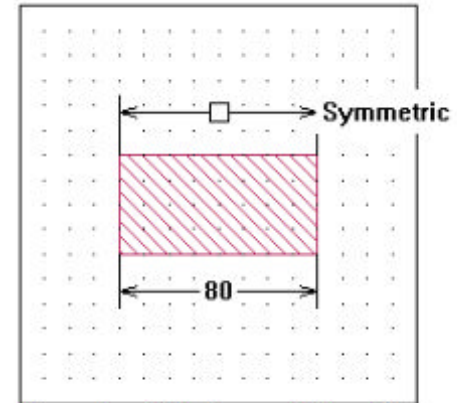

Nominal Value = 80 mils

Radial

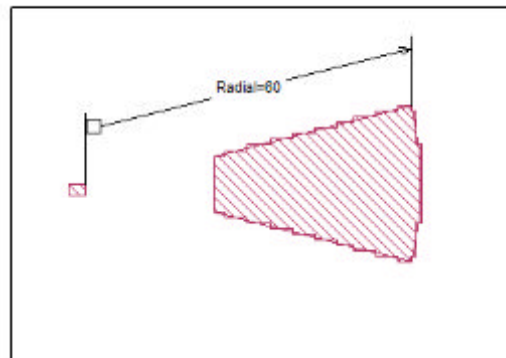

Nominal Value = 60 mils

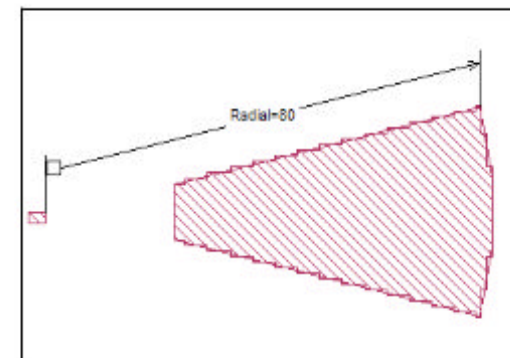

Nominal Value = 80 mils

1. Anchored Parameter

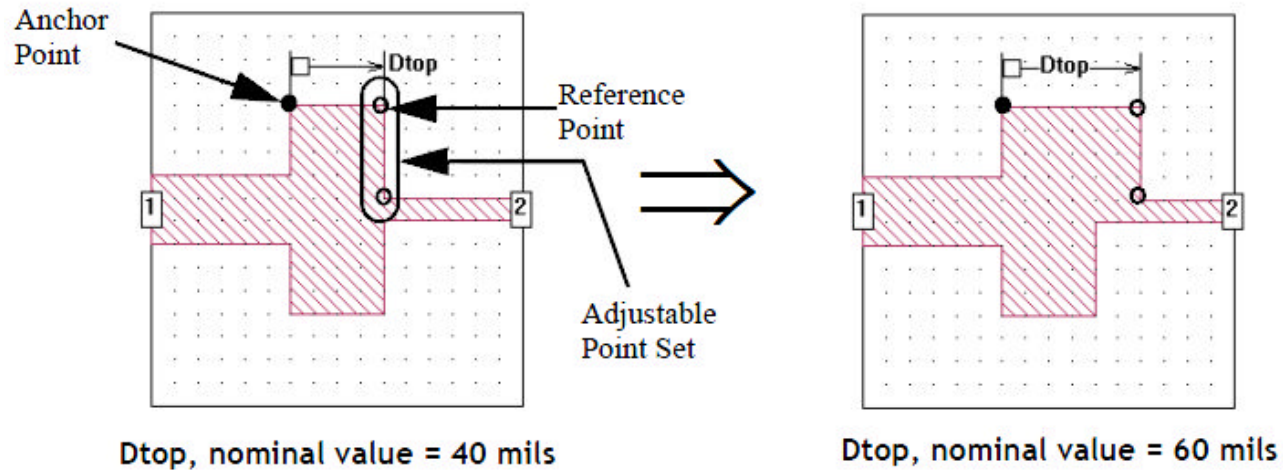
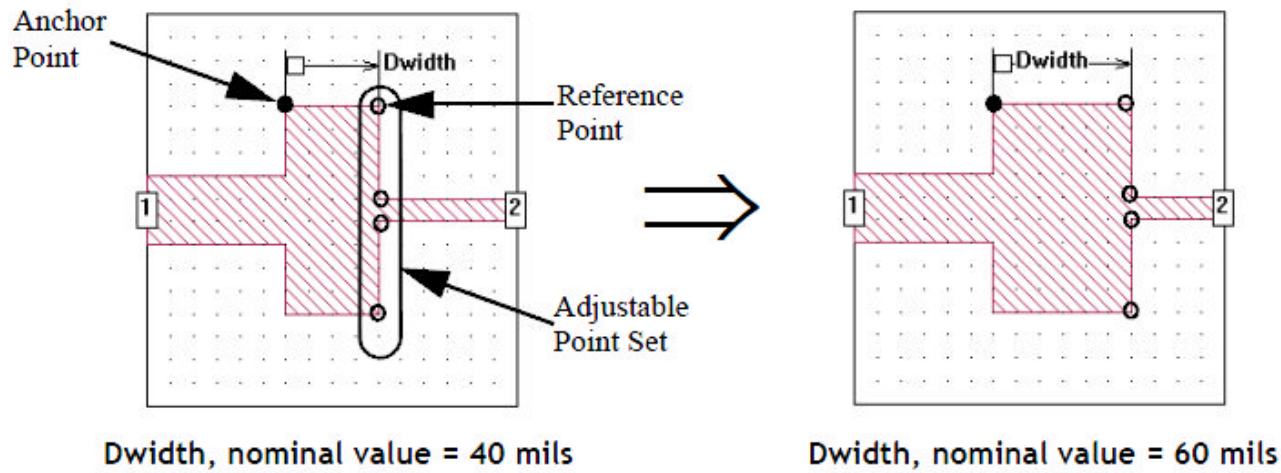

2. Symmetrical Parameter

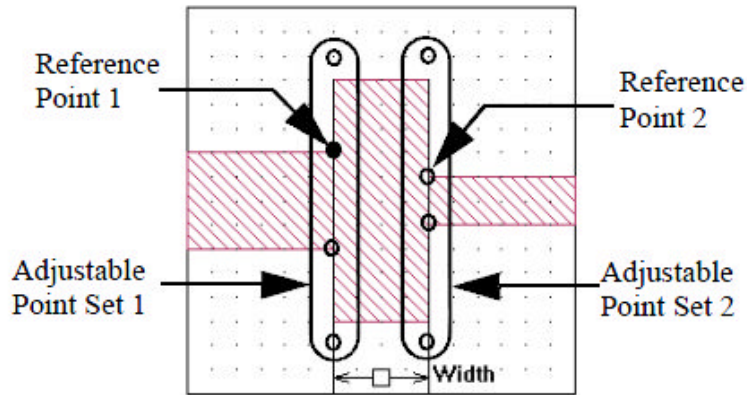

Width, nominal value = 40 mils

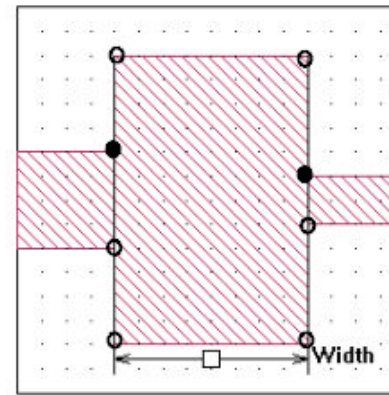

Width, nominal value = 80 mils

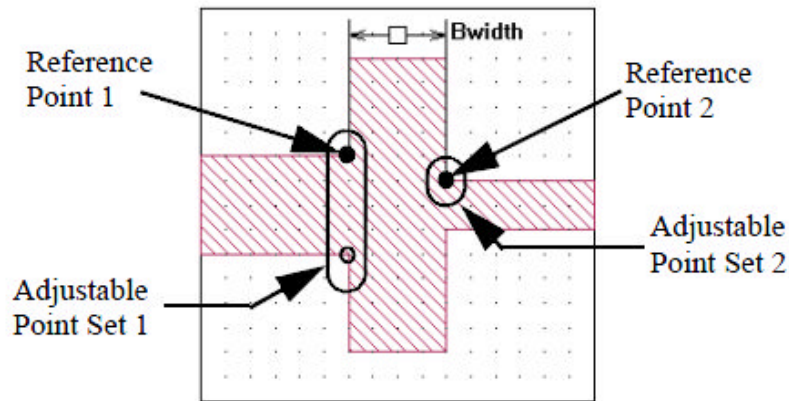

Bwidth, nominal value = 40 mils

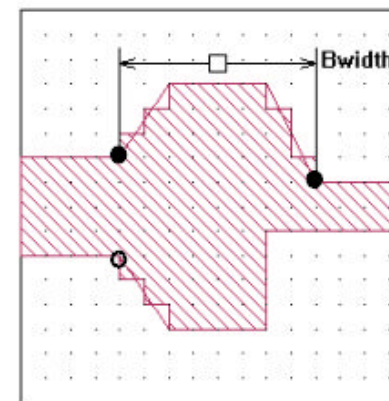

Bwidth, nominal value = 80 mils

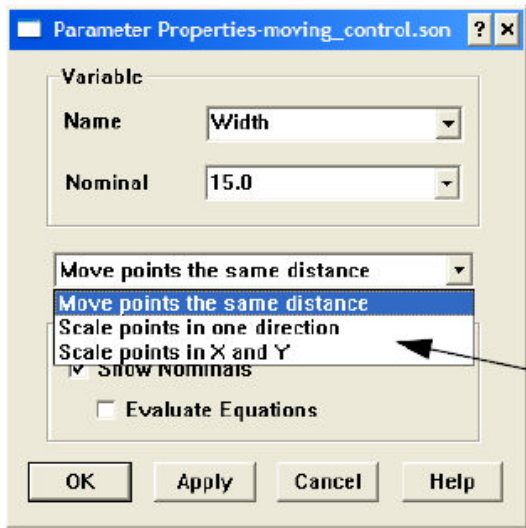

This is the Parameter Properties dialog box in which you select the moving option from the drop list shown to the left. This dialog box appears when you are entering a dimension parameter or when you select the command *Modify* ⇒ *Parameter Properties* when a dimension parameter is selected.

Moving option drop list

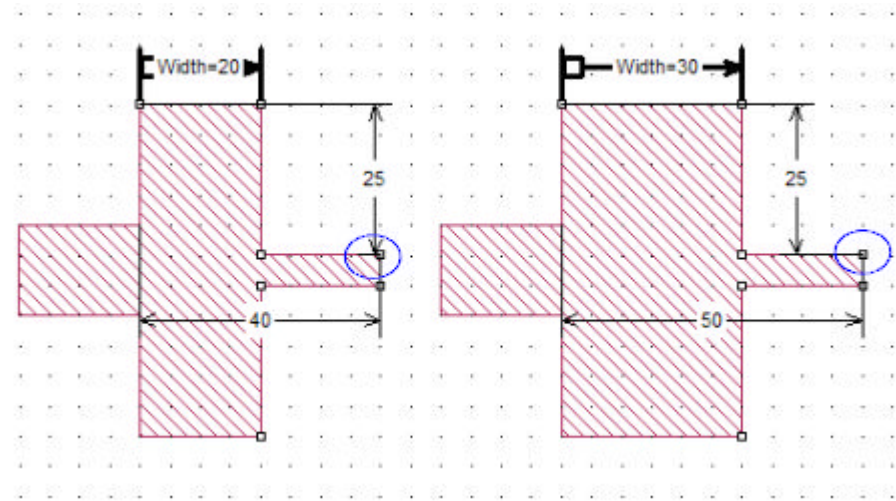

Default: Move points the same distance

Scale points in one direction

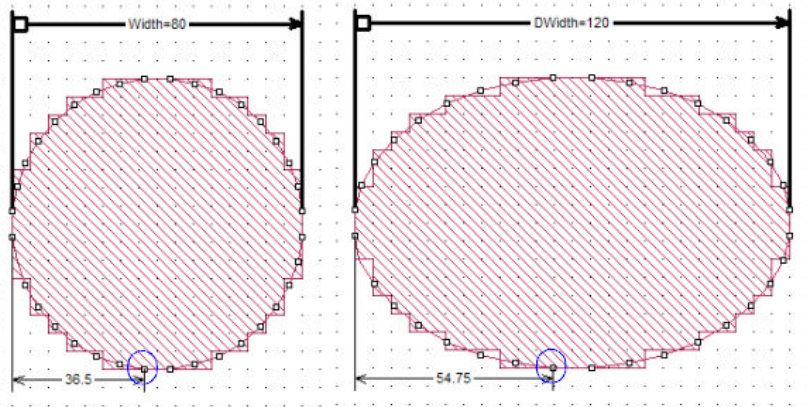

Scale points in x and y

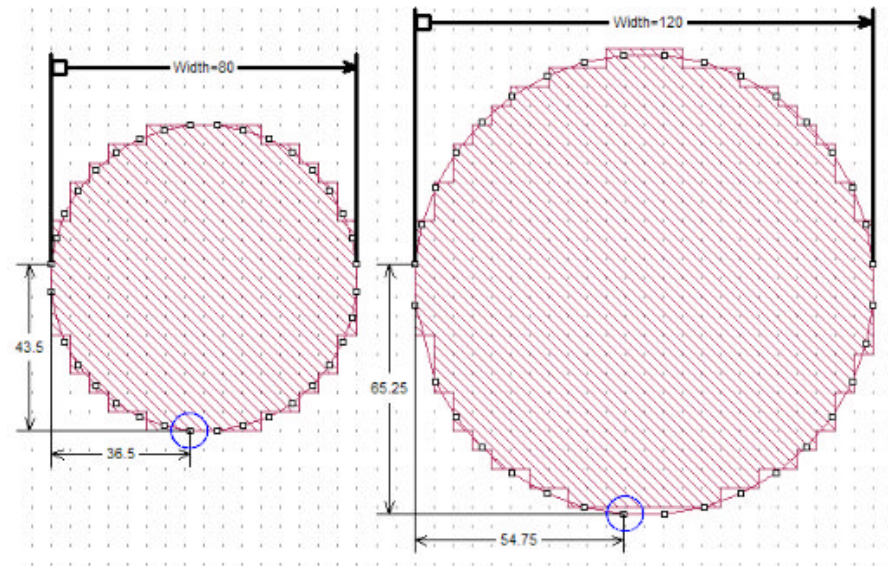

3. Radial

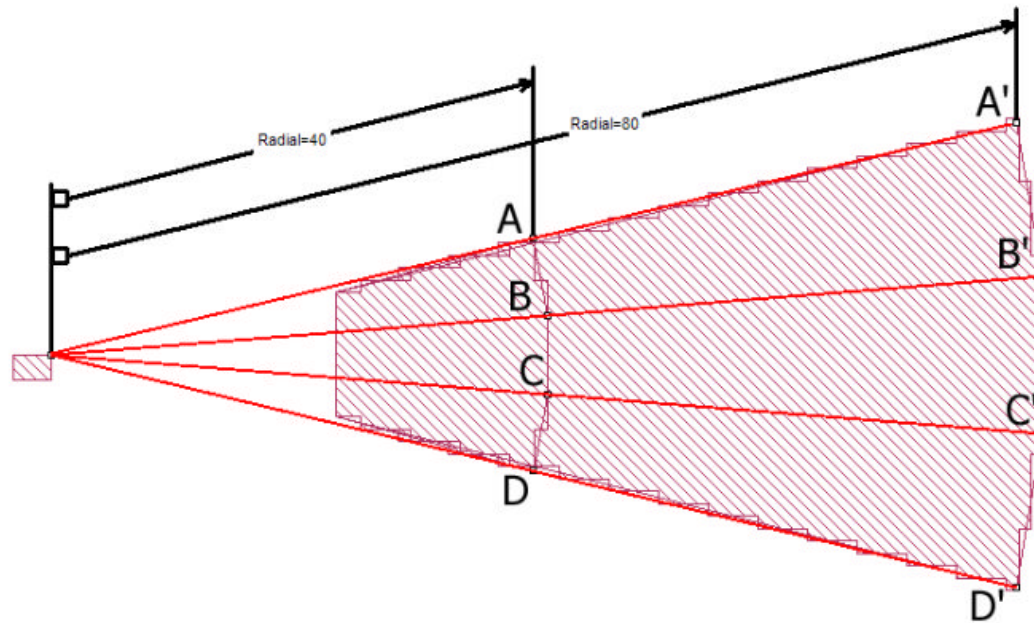
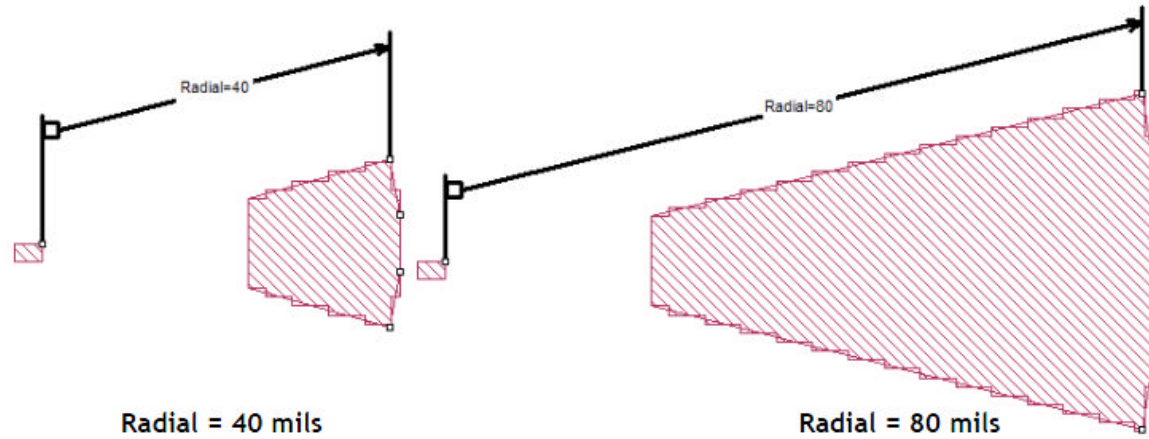

Dependent Parameters

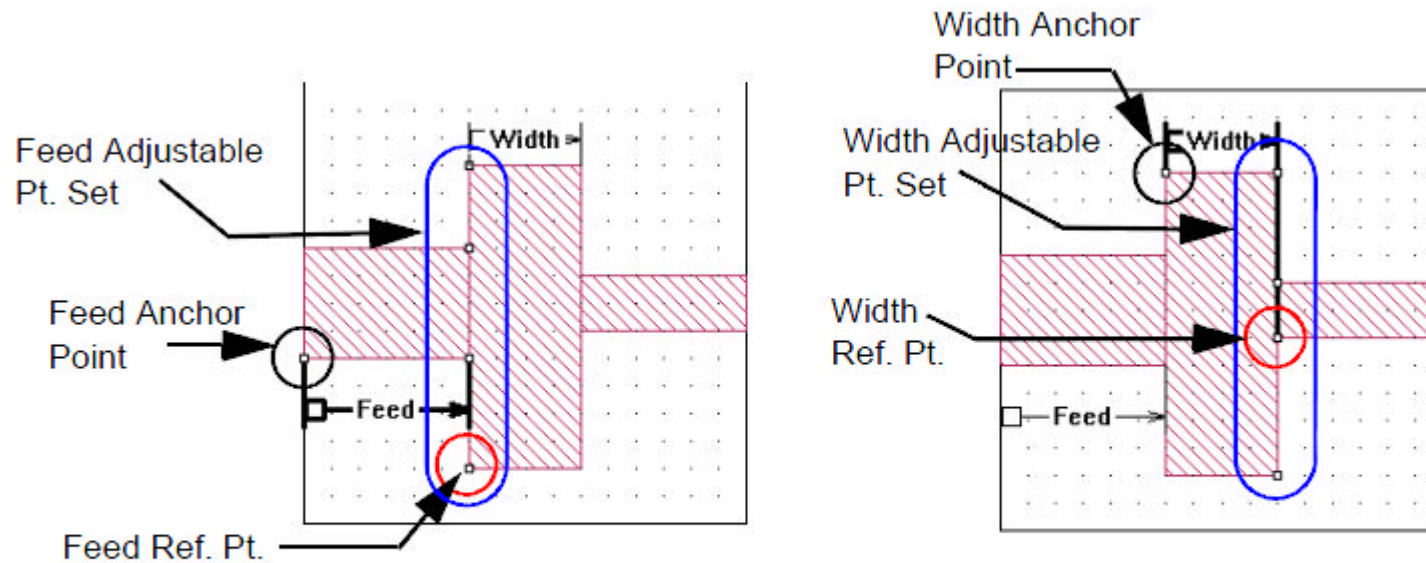

The dimension parameter “Width” is dependent on the dimension parameter “Feed”. Note that the anchor point for the dimension parameter “Width”, shown on the right, is part of the adjustable point set for the dimension parameter “Feed,” shown on the left.

Circular Dependencies

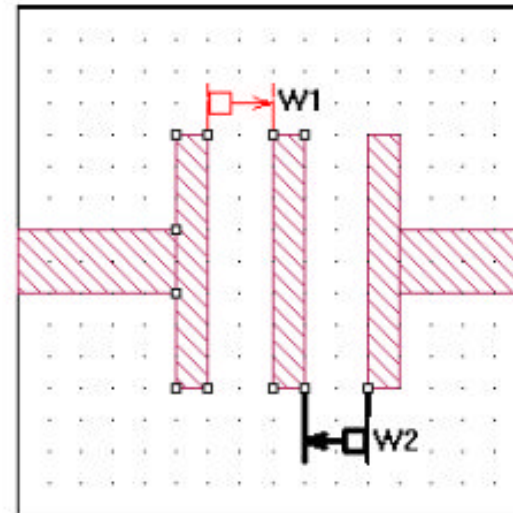
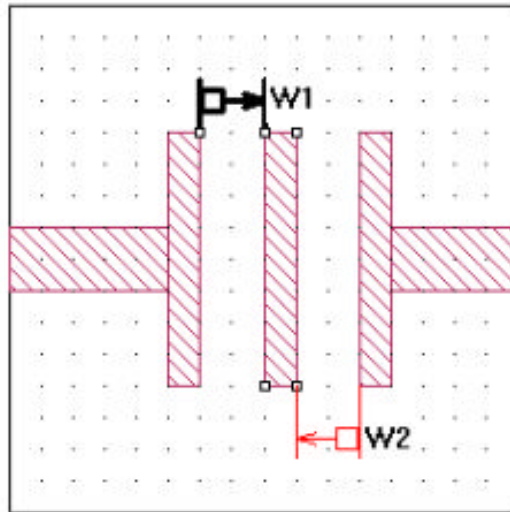

The middle section depends on W1 and W2.

When W1 is changed, the middle section moves, so that W2 must also change.

This conflict must be resolved by defining the parameters differently.

For example, both W1 and W2 can be defined „from left to right“.

Variables

- A variable's value may be defined using:
 - Constant or nominal value
 - Another variable
 - An equation

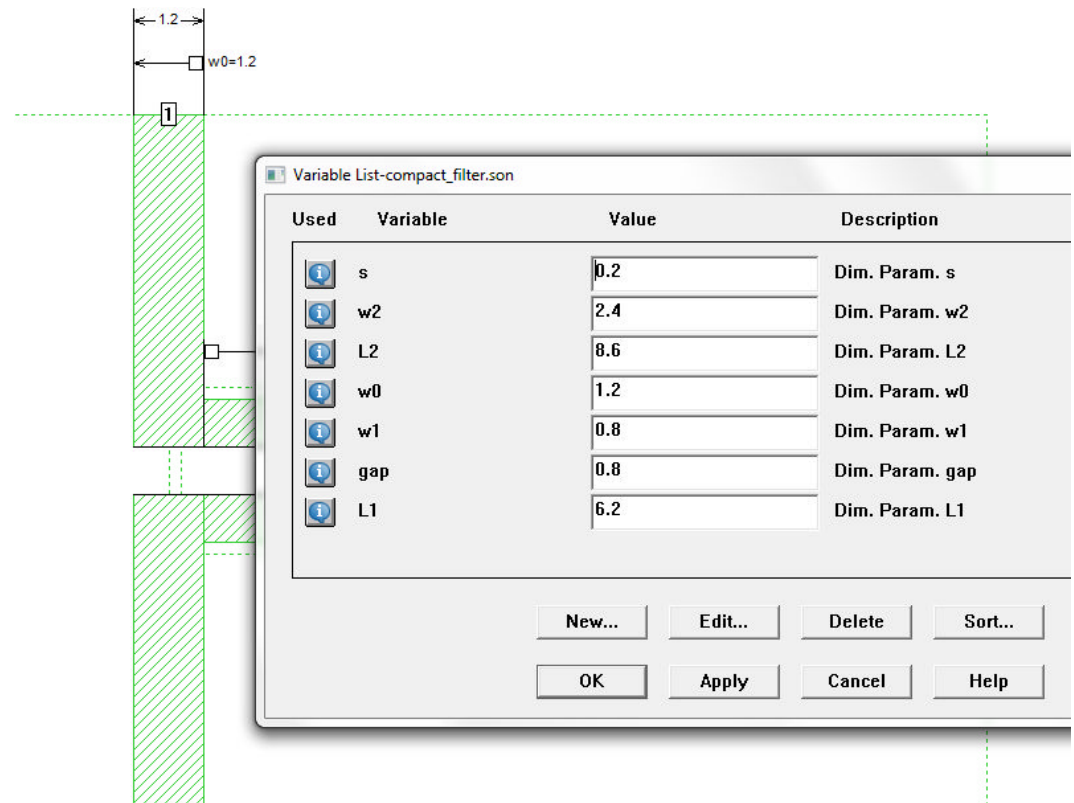

Equations

The image shows a software interface for defining variables. On the left, a diagram of a filter section is shown with a green hatched area labeled '1'. Two dialog boxes are overlaid on the diagram.

The top dialog box, titled "Variable List-compact_filter.son", displays a table of variables:

Used	Variable	Value	Description
<input type="checkbox"/>	s	0.2	Dim. Param. s
<input type="checkbox"/>	w2	2.4	Dim. Param. w2
<input type="checkbox"/>	L2	8.6	Dim. Param. L2
<input type="checkbox"/>	w0	1.2	Dim. Param. w0
<input type="checkbox"/>	w1	0.8	Dim. Param. w1
<input type="checkbox"/>	gap	0.8	Dim. Param. gap
<input type="checkbox"/>	L1	6.2	Dim. Param. L1
<input type="checkbox"/>	12+L1	12+L1	length of input section

The bottom dialog box, titled "Add/Edit Variable-compact_filter.son", is used to define a new variable. It contains the following fields:

- Name: MyLength
- Value or Equation: 12+L1
- Evaluates to: 18.2
- Description: length of input section
- Units: Other

The dialog also includes an "Available Variables" list with the following items: L1, L2, gap, s, w0, w1, w2. A button "Insert into Eqn" is located below the list.

At the bottom of the dialog, there is a note: "To learn how to use variables to vary things like dielectric constant press Help." and buttons for "OK", "Cancel", and "Help".

Variables in Material Properties

- Variables and equations can also be used in material properties:
 - conductivity, epsilon, $\tan\delta$, ...
 - conductor thickness
 - dielectric thickness
 - and others ...

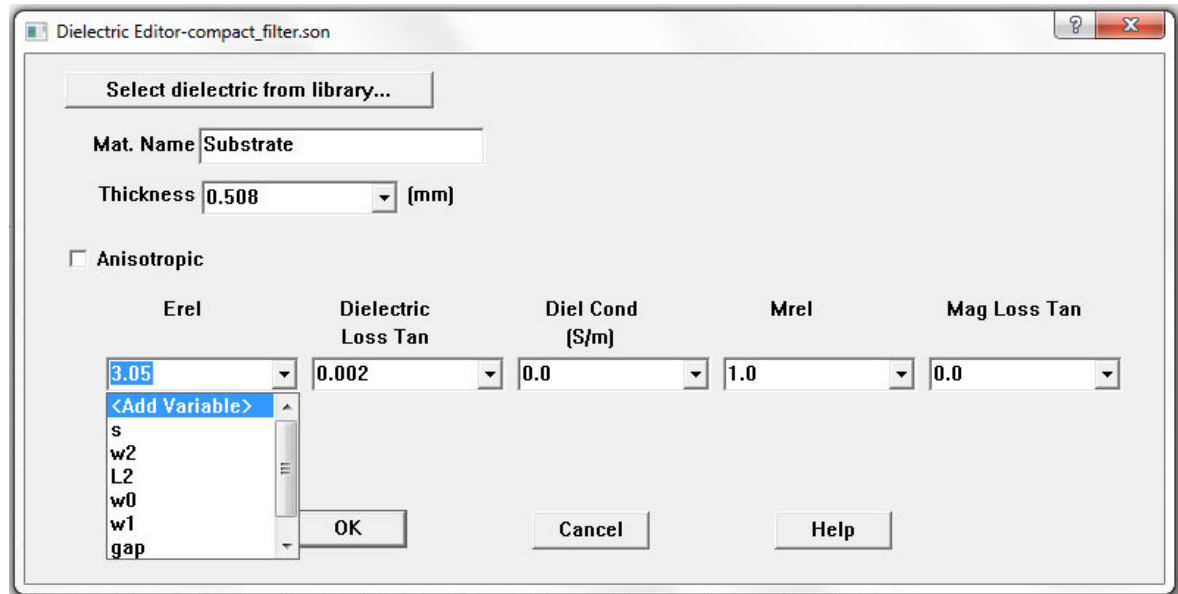

Parameter Sweep

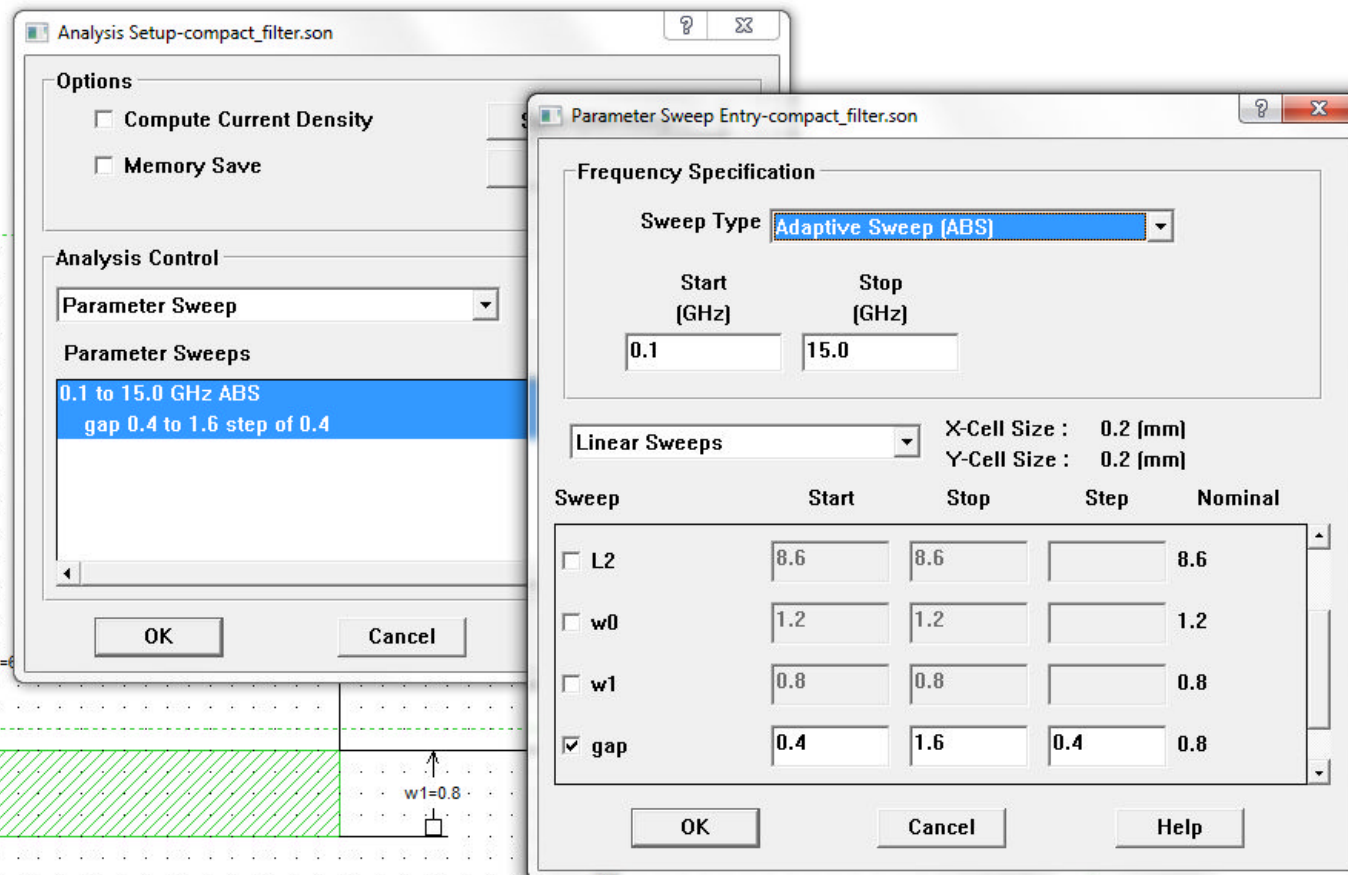

Geometry Parameter Sweep

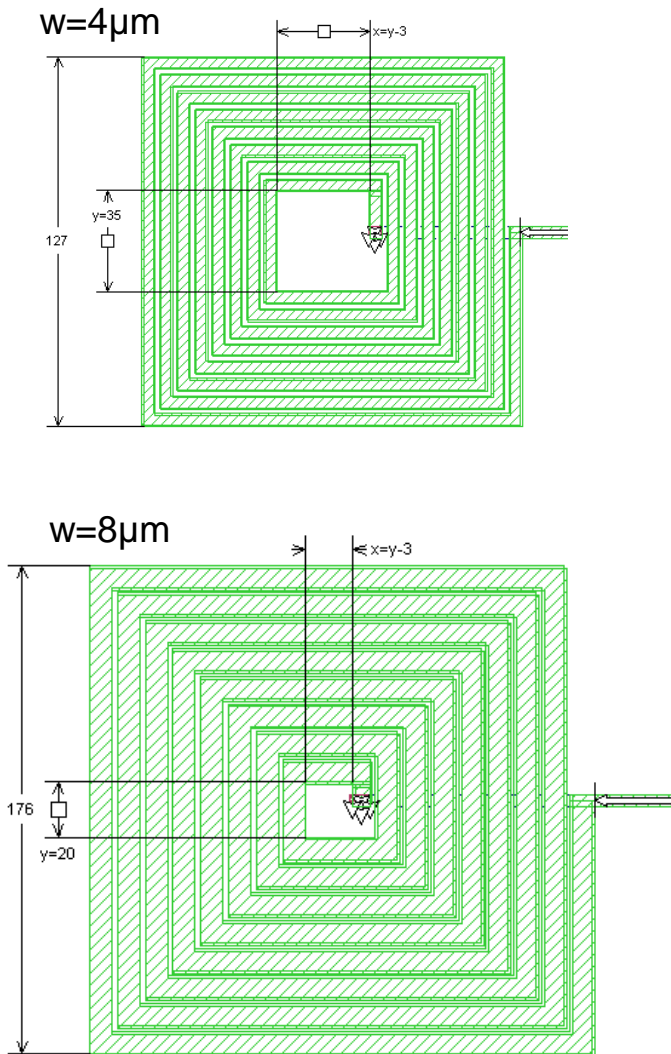

Inductance vs. center diameter

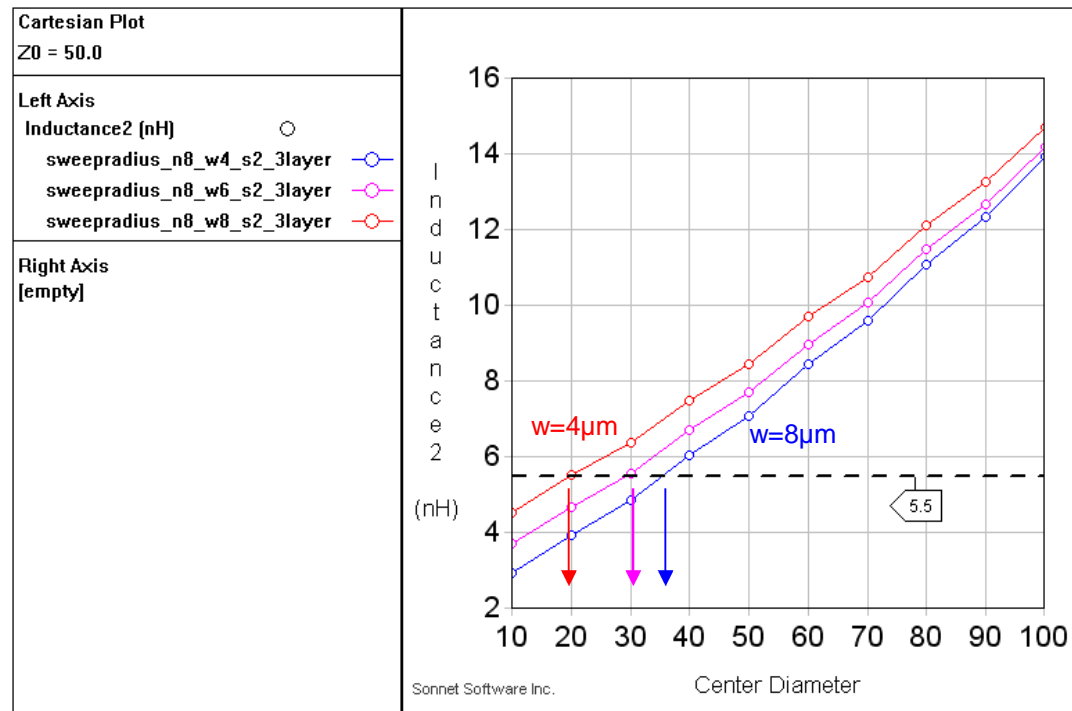

x-axis is center diameter

Output Files for Sweep Results

- Sonnet can create a set of S-parameter files, or you can save all sweep results into one MDIF file.
- ADS and Microwave Office can handle MDIF files. Examples are available.

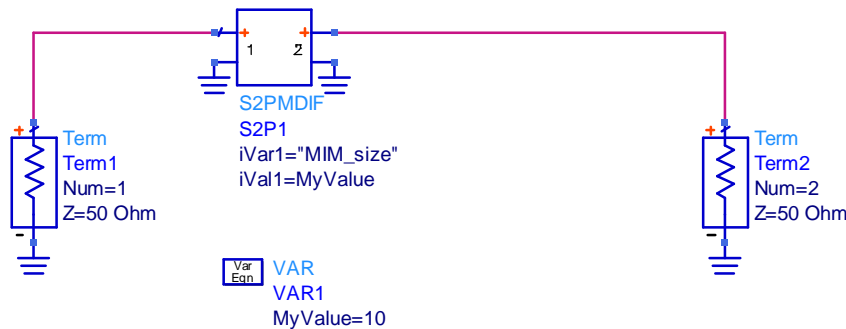

S-PARAMETERS

S_Param
SP1
Start=10 GHz
Stop=50 GHz
Step=10 GHz

PARAMETER SWEEP

ParamSweep
Sweep1
SweepVar="MyValue"
Start=5
Stop=70
Step=5

```
VAR MIM_size=5.0
VAR shapefactor=1.0
VAR w_feed=2.0
VAR distance_bottom_contactring=10.0
VAR dist_boxwall=30.0
VAR d1=0.6
VAR d2=0.77
BEGIN ACDATA
# hz s ma r 50
% f N11X N11Y N12X N12Y N21X N21Y N22X N22Y
1.0e8 0.999998 -0.09948 0.001618 89.90468 0.001618 89.904
END ACDATA
```

```
VAR MIM_size=6.0
VAR shapefactor=1.0
VAR w_feed=2.0
VAR distance_bottom_contactring=10.0
VAR dist_boxwall=30.0
VAR d1=0.6
VAR d2=0.77
BEGIN ACDATA
# hz s ma r 50
% f N11X N11Y N12X N12Y N21X N21Y N22X N22Y
1.0e8 0.999997 -0.14225 0.002346 89.86153 0.002346 89.861
END ACDATA
```