

Overview

Spiral Inductor Assistant for Sonnet is designed for fast and accurate on-the-fly design and analysis of planar inductors. Based on a pre-defined technology template file, the user only needs to define a few parameters to get a fully functional simulation model of the inductor. The simulation model can be opened in the Sonnet editor and analyzed with a few mouse clicks, to obtain key parameters like inductance, Q factor, series resistance and substrate parasitics.

With the appropriate Sonnet options, a broad band SPICE model can be extracted.

The Lite version of Spiral Inductor Assistant for Sonnet is limited to single ended inductors and is only available for Windows. The Professional version does also support differential (symmetrical) inductors and is available for Windows and Linux platforms.

Setup (Windows version)

To install Spiral Inductor Assistant for Sonnet, run setup.exe.

To uninstall, remove the program with the Software applet from the control panel.

Getting started

Before you can start creating spiral inductors, you must configure a technology template file. The technology template file defines the dielectric stackup, the inductor and bridge layers, the respective conductor materials and also the simulation settings like box size, cell size and frequency range.

You can use any Sonnet project as a template. Existing geometries in that file will be ignored. To choose a template file, click on the Open... button and browse to an existing Sonnet file.

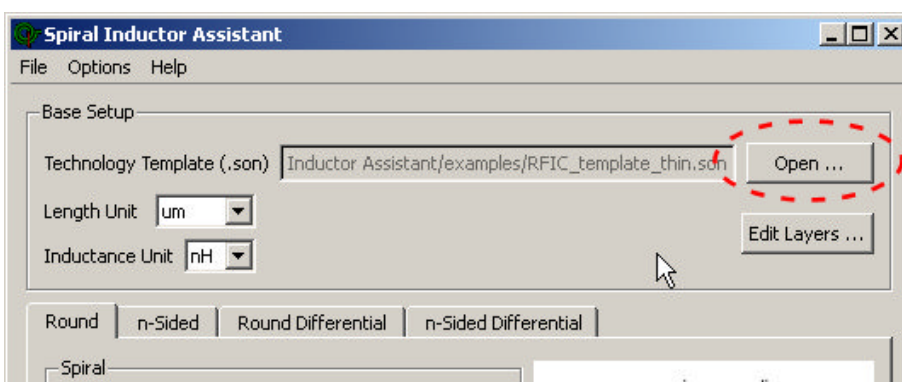

The length unit used by Spiral Inductor Assistant is automatically read from the template file. If you prefer different units, you can change the length and inductance unit from the drop down list.

Next, click on the “Edit Layers” button.

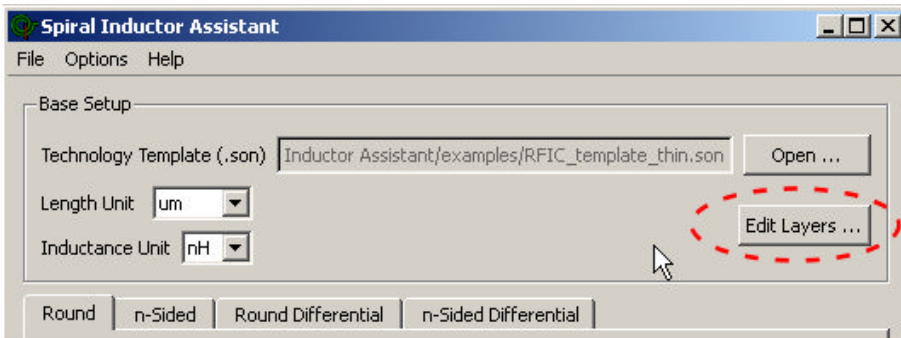

The dielectric layer configuration is read from the template, but we still need to define the vertical position of the inductor layer(s) and bridge layer(s) and materials. This is done in the “Edit Layers ...” dialog.

In the “Function” column, the purpose of each possible metal layer is defined: none, spiral or bridge. It is also allowed to define multiple layers for bridge and spiral. In the “Metal Layer” column, a metal type is chosen for the respective layer. You can choose from all metal types available in the template file.

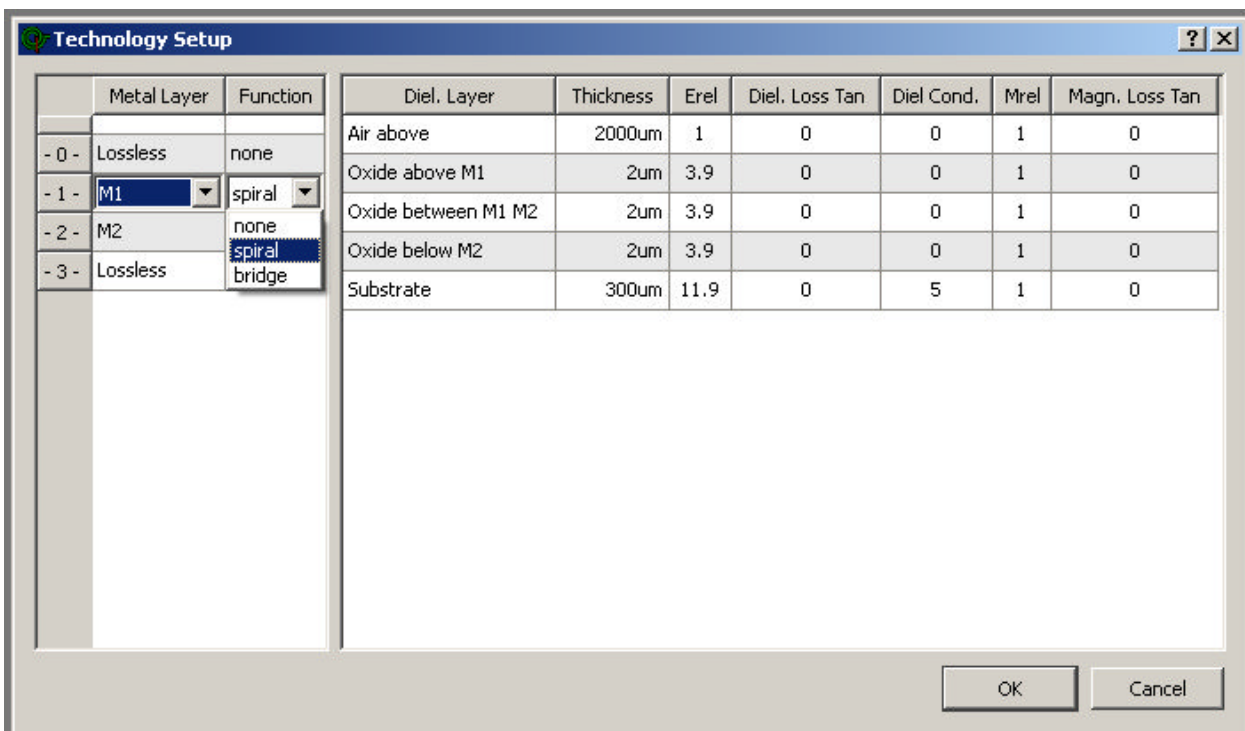

When you have assigned bridge and spiral position and metal type, leave the dialog with the OK button. You will be asked if you want to save those changes to the template file. These Spiral Inductor Assistant specific assignments will be stored in the Comments field of the Sonnet project. It will also be included in the output files created

with Spiral Inductor Assistant, so you can use the output files as template files for other inductors, too.

Please note: In the “Edit Layers ...” dialog, no changes can be made to the dielectric layer stackup and metal type definitions. If necessary, you must make those changes in the template file.

Create spiral inductor models

When the setup of technology and layer assignment is completed, you are ready to create spiral inductor models. In the Lite version, you can choose between circular spiral and n-sided spiral. The spiral will be created in the center of the analysis box, with the box size and cell size as defined in the template file.

A bridge will connect the inner turn of the spiral with the right box wall, connected to box wall port 2. The other end will be connected to port 1, at one of the side walls depending on the number of turns. For a n.5 turn spiral, port 1 will be on the left side on the spiral level, and port 2 will be on the right side on the bridge level.

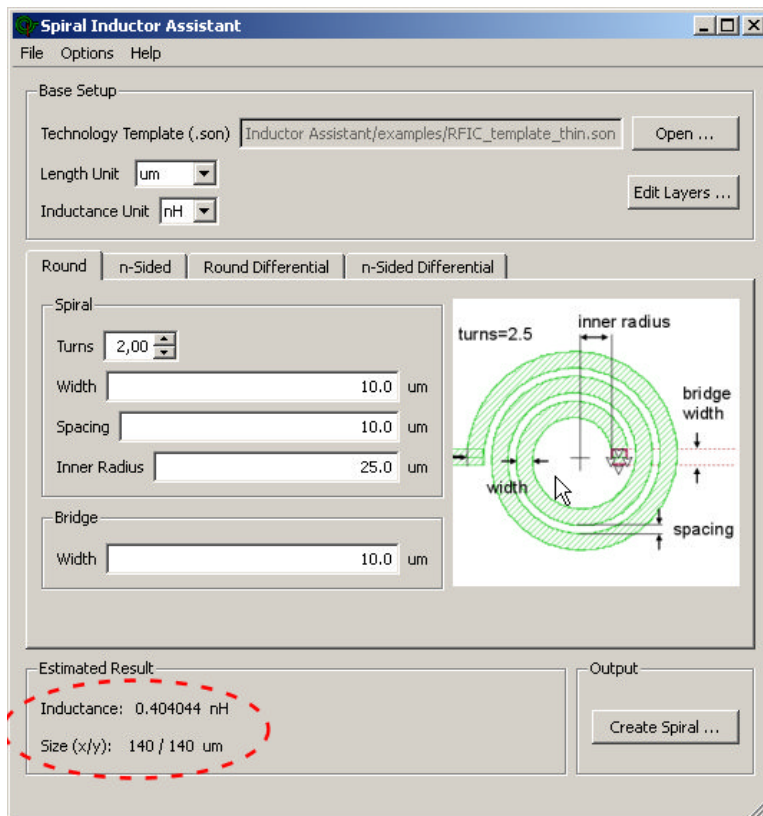

The estimated inductance for the given dimensions is displayed near the “Create” button. Please note that this is only an estimate and does not take into account a conducting substrate.

When the estimated inductance meets your requirements and you want to create the Sonnet model, press “Create...” and enter the output file name.

The Spiral Inductor Assistant will create the Sonnet model file and try to open it in the Sonnet xgeom editor.

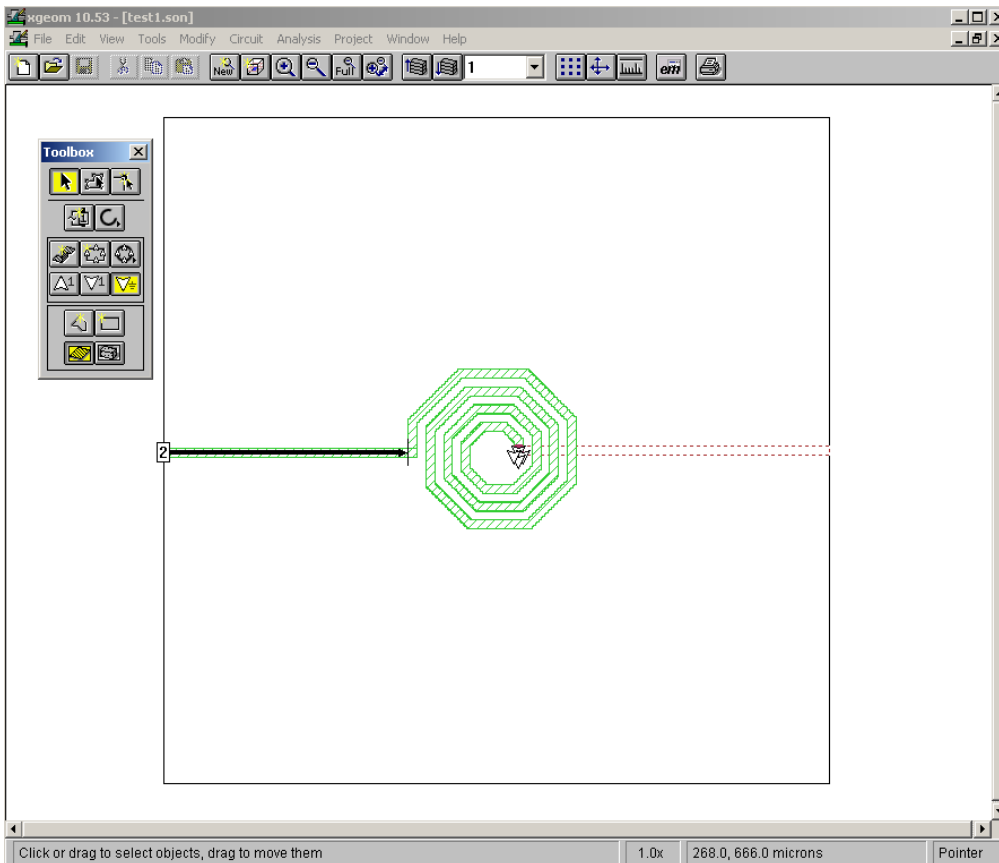

If you have not specified a location for the Sonnet xgeom editor, it will automatically search your computer's program files folder to find the Sonnet installation and the editor location. In the Options menu, you can change the location of the xgeom editor (required if you have multiple Sonnet version installed) and configure the "Launch xgeom on Create" behaviour.

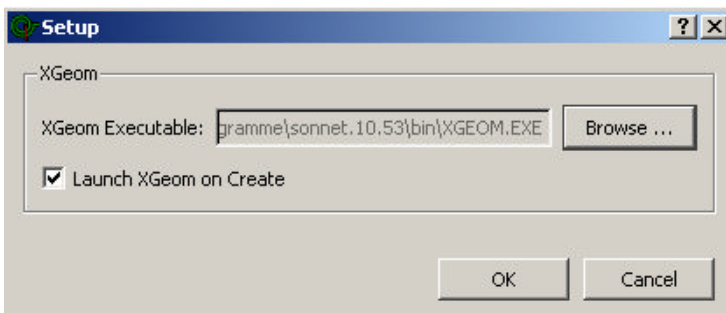

Differential spirals

The Lite version of Spiral Inductor Assistant for Sonnet is limited to single ended inductors and is only available for Windows. The Professional version does also support differential (symmetrical) inductors and is available for Windows and Linux platforms.

Two types of differential inductors are available: round and n-sided. For round differential spirals, a straight crossover section is inserted between the arcs. For n-sided differential spirals, typical shapes are rectangular (4 sides) and octagonal (8 sides), but other configurations are possible.

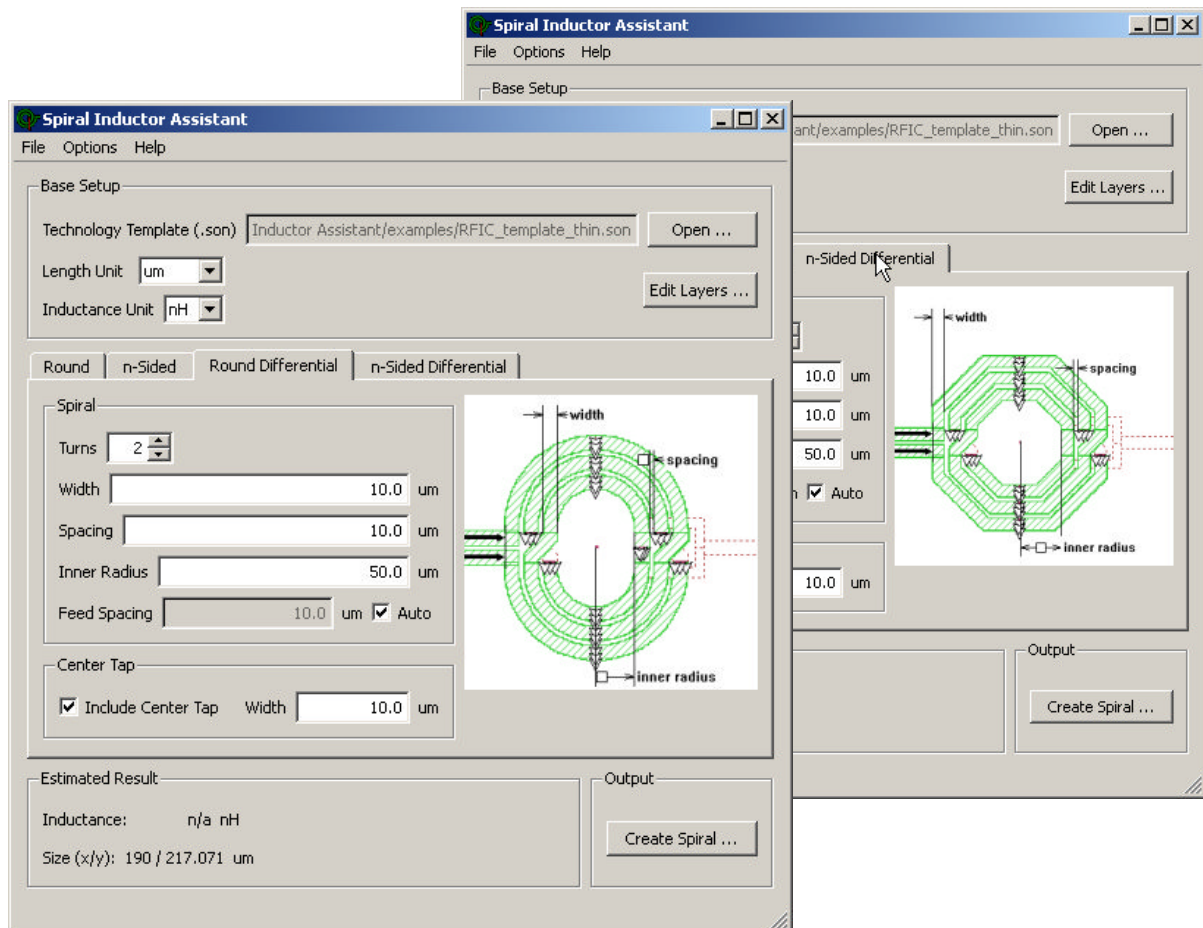

When multiple layers are connected in parallel for the coil, connections between the layers are created in the crossover section and half way between the crossovers.

An optional center tap can be included, which is connected to Sonnet port 3. The connection to the center tap is created on the bridge level, forming a ring around the crossover section.

Estimated inductance is not displayed for differential spirals.

Using the analysis result

When the Sonnet analysis is finished, you can display the analysis results in various ways. To assist you in plotting the typical inductor values, we have supplied a set of equations for the Sonnet data display “emGraph” that plot the equivalent Pi model components.

- Q factor
- Series inductance between port 1 and 2
- Series resistance between port 1 and 2
- Shunt capacitance from port 1 to ground (substrate) assuming series R-C
- Shunt capacitance from port 2 to ground (substrate) assuming series R-C
- Shunt resistance from port 1 to ground (substrate) assuming series R-C
- Shunt resistance from port 2 to ground (substrate) assuming series R-C

The equation file can be loaded into the emGraph data display manually, or automatically when the data display is started. The equation file is located in the Spiral Inductor Assistant program folder (C:\Program Files\Spiral Inductor Assistant\emGraph inductor extraction\rfic_inductor.sqn).

In the Sonnet emGraph data display, go to Equations > Manage Equations and then “Open ...” the equation file for single use, or specify it as “Load this file on startup” so that it is always loaded when the emGraph data display starts.

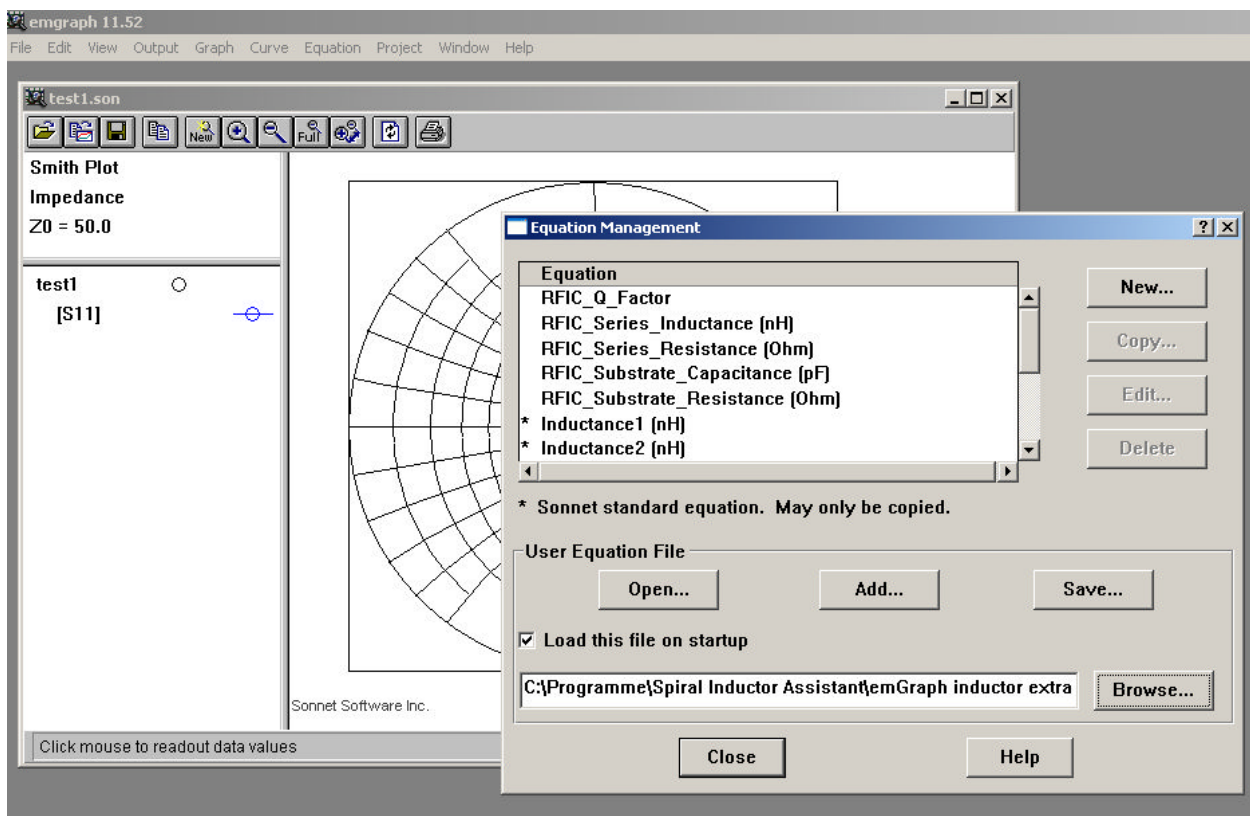

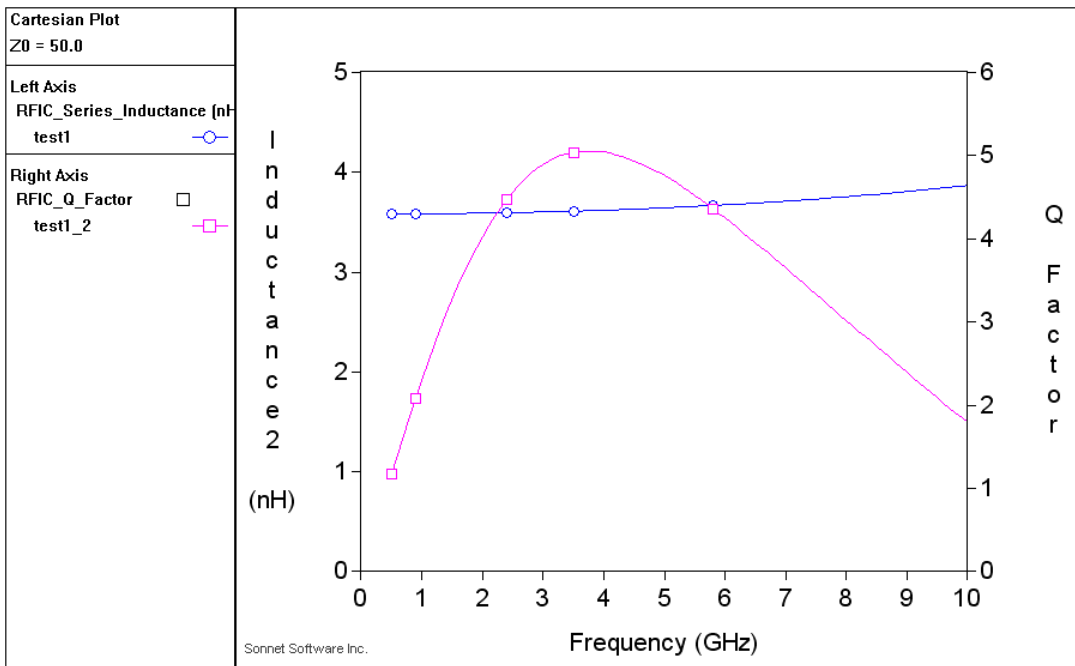

Please note that the extracted values are only valid within the limits of the underlying simple Pi model. For example, substrate return current in a lossy substrate will create seemingly negative series resistance. The underlying S-parameters are perfectly valid, and this is only an extraction issue. It is a limit of the underlying Pi model extraction, which does not model the substrate return current properly. The negative series resistance that you see is non-physical, because it is a composite from physical resistance in the coil and from substrate return current.

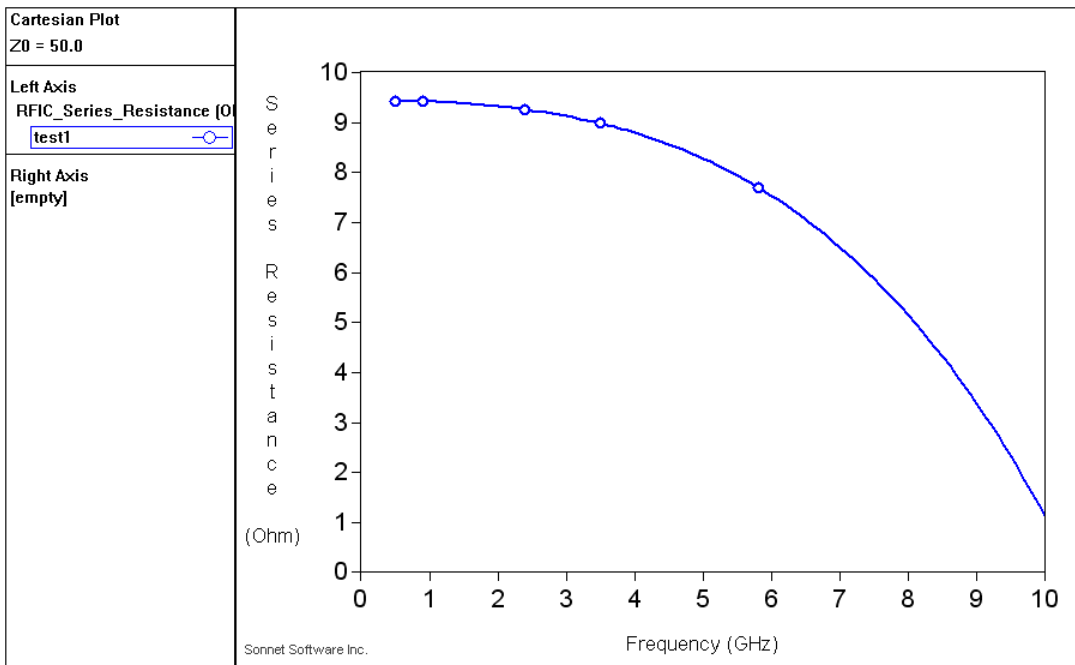

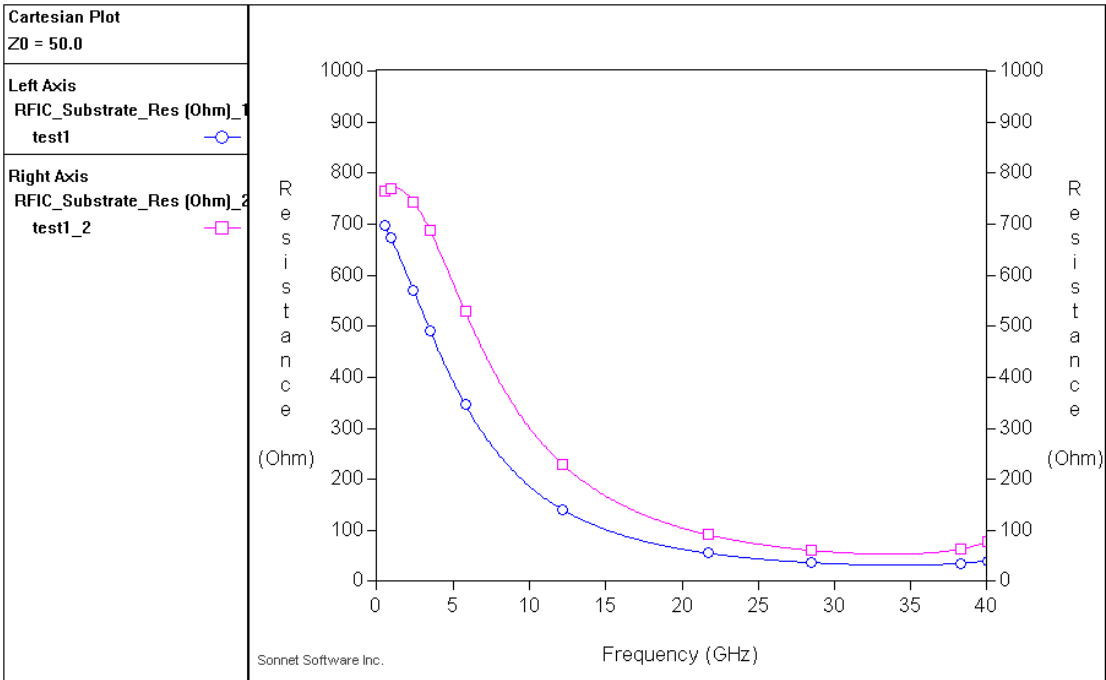
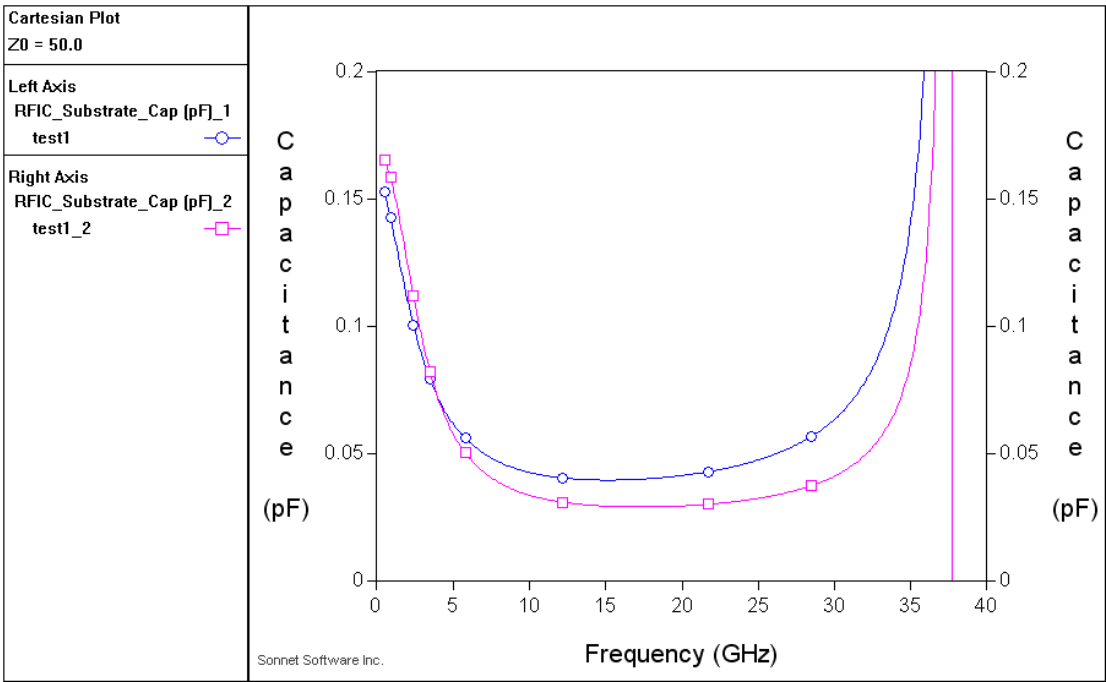

Settings used by the Spiral Inductor Assistant

Values from the template:

- Units
- Box size
- Cell size
- Dielectric materials and stackup
- Metal types and metal definitions
- Frequency settings
- Advanced analysis settings
- Spiral and Bridge mapping from Comment field, if available

Values assigned by Spiral Inductor Assistant:

- Staircase mesh for 4-sided spiral
- Conformal mesh for all other spirals

User License and Disclaimer of Warranties

MUEHLHAUS HOCHFREQUENZTECHNIK END USER LICENSE AGREEMENT FOR SPIRAL INDUCTOR ASSISTANT Lite

BY INSTALLING THIS SOFTWARE YOU ACCEPT ALL THE TERMS AND CONDITIONS OF THIS AGREEMENT.

This Muehlhaus Hochfrequenztechnik ("Muehlhaus") End User License Agreement accompanies the SPIRAL INDUCTOR ASSISTANT Lite software and related explanatory materials including product documentation ("Software"). The term "Software" also shall include any upgrades, modified versions or updates of the Software licensed to you by Muehlhaus. Please read this Agreement carefully. At the end, you will be asked to accept this agreement and continue to install or, if you do not wish to accept this Agreement, to decline this agreement, in which case you will not be able to use the Software.

Upon your acceptance of this Agreement, Muehlhaus grants to you a nonexclusive license to use the Software, provided that you agree to the following:

1. Use of the Software.

You may install the Software on a hard disk or other storage device; install and use the Software on a file server for use on a network for the purposes of (i) permanent installation onto hard disks or other storage devices or (ii) use of the Software over such network; and make backup copies of the Software.

2. License Grant.

Muehlhaus provides you, as a Sonnet customer, with a license for the Spiral Inductor Assistant Lite Software, and you may use that version of the software in accordance with the terms and limitations of this Agreement.

3. Copyright and Trademark Rights.

The Software is owned by Muehlhaus, and its structure, organization and code are valuable trade secrets of Muehlhaus. The Software also is protected by German Copyright Law and International Treaty provisions. You may use trademarks only insofar as required to comply with Section 1 of this Agreement and to identify printed output produced by the Software, in accordance with accepted trademark practice, including identification of trademark owner's name. Such use of any trademark does not give you any rights of ownership in that trademark. Except as stated above, this Agreement does not grant you any intellectual property rights in the Software.

4. Restrictions.

You agree not to modify, adapt, translate, reverse engineer, decompile, disassemble or otherwise attempt to discover the source code of the Software. You may not alter or modify the installer program or create a new installer for the Software. You may not bundle this software with other software packages without prior written permission from Muehlhaus. You may not use the Software to publish comparisons to other electromagnetic software products without prior written permission from Muehlhaus. You agree not to use the Software to aid in the design or modification of any commercial EDA product without prior written permission from Muehlhaus.

5. Termination.

Muehlhaus may terminate this license upon written notice at any time and for any reason. If, additionally, terms of this license have been violated, Muehlhaus' remedies shall not be construed as limited to termination.

6. No Warranty.

The Software is being delivered to you AS IS and Muehlhaus makes no warranty as to its use or performance. MUEHLHAUS DOES NOT AND CANNOT WARRANT THE PERFORMANCE OR RESULTS YOU MAY OBTAIN BY USING THE SOFTWARE OR DOCUMENTATION. MUEHLHAUS MAKES NO WARRANTIES, EXPRESS OR IMPLIED, AS TO NONINFRINGEMENT OF THIRD PARTY RIGHTS, MERCHANTABILITY, OR FITNESS FOR ANY PARTICULAR PURPOSE. IN NO EVENT WILL MUEHLHAUS BE LIABLE TO YOU FOR ANY CONSEQUENTIAL, INCIDENTAL OR SPECIAL DAMAGES, INCLUDING ANY LOST PROFITS OR LOST SAVINGS, EVEN IF A MUEHLHAUS REPRESENTATIVE HAS BEEN ADVISED OF THE POSSIBILITY OF SUCH DAMAGES, OR FOR ANY CLAIM BY ANY THIRD PARTY. Some states or jurisdictions do not allow the exclusion or limitation of incidental, consequential or special damages, or the exclusion of implied warranties or limitations on how long an implied warranty may last, so the above limitations may not apply to you.

7. Governing Law and General Provisions.

This contract, and all questions concerning its performance, validity, and interpretation shall be governed by the law of the Federal Republic of Germany. If any provision of this contract is, or becomes, invalid, this shall have no effect on the validity of the remaining provisions. Further, the parties shall, if possible, replace the invalid provision with a new, valid provision that fulfils as closely as possible the original intent of the invalid provision. The courts of Bochum shall have jurisdiction for all disputes out of and arising from this Agreement.

You agree that the Software will not be shipped, transferred or exported into any country or used in any manner prohibited by export laws, restrictions or regulations. This Agreement shall automatically terminate upon failure by you to comply with its terms. This Agreement may only be modified in writing signed by an authorized officer of Muehlhaus.

Sonnet and em are registered trademarks of Sonnet Software Incorporated.

Copyright 2007 Muehlhaus Hochfrequenztechnik

Dr. Muehlhaus Consulting & Software GmbH
Drosselweg 11, 58455 Witten, Germany
www.muehlhaus.com